

POWERVERTER PVPro A & C Range

12/24VDC USB CHARGERS

A & C PORT USB CHARGING FOR 12V AND 24VDC APPLICATIONS

The PowerVerter PVPro Range of USB chargers has been completely updated into the A & C Range, amalgamating all the great design concepts of USB charging on vehicles into one simple range. Models are now available offering both USB A and C connections, including Single and Double A as well as Single and Double C and a combined Dual A & C output version.

As well as standard (rear fit), all models are available in front fit versions. This is a popular option for when rear space access is limited, and also allows for quick removal and replacement if required.

Ingress protection is to IP30 as standard. However, the PVPWp versions retain the slimline design and offer enhanced protection to IP65 (not connectors). The ruggedised PV65R versions which are also IP65 (not connectors), offer additional transient protection and are particularly suitable in more demanding environments such as for installation into vehicle walls.

Output power performance has also been enhanced. As well as charging both Apple and Android mobile phones, the USB-C models offer higher current outputs for limited charge assistance on tablets and laptops.

Standard versions require only 20mm (typical) rear space and can easily be installed in bus and coach seat backs, walls and dashboards. A series of 3 pod designs enable retrofit options for underseat, table and wall mounting.

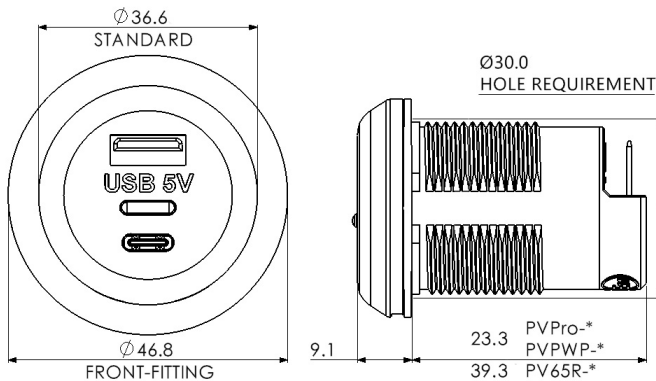

THE RANGE

All units are installed through a 30mm hole. Standard format units are retained by a rear nut while the front fit versions include a bezel with tamperproof cover ring. Input power is by way of two 6.3mm push-in flat fit automotive terminals.

Dimensionally the USB A and C Chargers are the same and are interchangeable with the ever-popular PVPro Range. Electronically the designs include reverse polarity protection and automatic short circuit protection, so in the event of tampering or compromise the unit will shut down, then restart again, once the fault has been removed.

SAFETY

A requirement of the USB standard is that the metal cage around the USB plugs and sockets is connected to ground (zero volts). If a USB charger is to be used in an application with a positive ground, i.e. battery/supply positive terminal is connected to the vehicle chassis, then there is a risk that the exposed metal cage of any USB cable could come in contact with the positive connected chassis, causing uncontrolled heating of the USB cable and USB charger and potentially creating a hazard.

In positive ground applications, we recommend installing an Alfatronix isolated converter between the positive ground supply and the input of the USB charger.

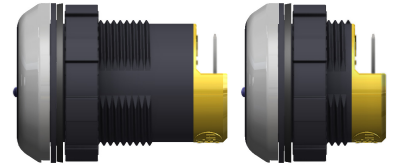

IP65 versions available
PV65R - ruggedised and PVPWp, both IP65 rated; indicated by yellow rear cap

The new A & C range has the following key benefits:

- Both type-A and type-C outputs
- Apple and Android compatible
- Dashboard, slimline seat back or underseat pod configurations
- LED output indicator
- IP30 or IP65 ingress protection -see Product Overview
- CE, E and UKCA marked



PVPro-A
Single output
A connector



PVPro-AA
Double output
A connector



PVPro-C
Single output
C connector



PVPro-AC
Dual output A
& C connector



PV-USB2-C: Charger only, no interface. For under-dash use. Also available with USB A connector.



All products are available in front fit options for when rear access is limited

WARRANTY

The PVPro A and C range of chargers are manufactured using rugged components to provide years of service in demanding commercial environments and are covered by a three year return to base guarantee.

CHOOSE YOUR USB PRODUCT

| PART NUMBER | DESCRIPTION | DIMENSIONS (mm) | WEIGHT |
|--|--|--|--------|
| Standard IP30 USB Chargers: | | | |
| PVPro-A | USB 'A' Single output 12/24-5V, 2.1A | Ø37 x 34; Hole Ø30; Rearspace typ.22 | 20g |
| PVPro-AA | USB 'A' & 'A' Dual output 12/24-5V, 3.0A | Ø37 x 34; Hole Ø30; Rearspace typ.22 | 24g |
| PVPro-AC | USB 'A' & 'C' Dual output 12/24-5V, 3.6A | Ø37 x 34; Hole Ø30; Rearspace typ.22 | 25g |
| PVPro-C | USB 'C' Single output 12/24-5V, 3.0A | Ø37 x 34; Hole Ø30; Rearspace typ.22 | 20g |
| PVPro-CC | USB 'C' & 'C' Dual output 12/24-5V, 3.0A | Ø37 x 34; Hole Ø30; Rearspace typ.22 | 21g |
| Ruggedised IP65 USB Chargers: | | | |
| PV65R-A | USB 'A' Single output rugged, IP65 12/24-5V, 2.1A | Ø37 x 49; Hole Ø30; Rearspace typ.36 | 36g |
| PV65R-AA | USB 'A' & 'A' Dual output rugged, IP65 12/24-5V, 3.0A | Ø37 x 49; Hole Ø30; Rearspace typ.36 | 39g |
| PV65R-AC | USB 'A' & 'C' Dual output rugged, IP65 12/24-5V, 3.6A | Ø37 x 49; Hole Ø30; Rearspace typ.36 | 36g |
| PV65R-C | USB 'C' Single output rugged, IP65 12/24-5V, 3.0A | Ø37 x 49; Hole Ø30; Rearspace typ.36 | 28g |
| Slimline IP65 USB Chargers: | | | |
| PVPWp-A | USB 'A' Single, slimline, IP65 12/24-5V, 2.1A | Ø37 x 34; Hole Ø30; Rearspace typ.22 | 26g |
| PVPWp-AA | USB 'A' & 'A' Dual, slimline, IP65 12/24-5V, 3.0A | Ø37 x 34; Hole Ø30; Rearspace typ.22 | 30g |
| PVPWp-AC | USB 'A' & 'C' Dual, slimline, IP65 12/24-5V, 3.6A | Ø37 x 34; Hole Ø30; Rearspace typ.22 | 29g |
| PVPWp-C | USB 'C' Single, slimline, IP65 12/24-5V, 3.0A | Ø37 x 34; Hole Ø30; Rearspace typ.22 | 24g |
| PVPWp-CC | USB 'C' & 'C' Dual output 12/24-5V, 3.0A | Ø37 x 34; Hole Ø30; Rearspace typ.22 | 25g |
| For front fit versions, please add the suffix Ff, e.g. PVPro-AFf, PV65R-CFf, PVPWp-ACFf. The detachable ring in both standard and front fit format can be customised for branding and advertising purposes. Please ask our sales team. | | | |
| Accessories: | | | |
| USB-POD | Underseat mounting pod for USB chargers | W 60, H 52, D 80 | 69g |
| USB-TPOD | Table mounting pod for 2x USB chargers | W 103, H 44.5, D 88 | 73g |
| USB-WPOD | Wall mounting pod for USB chargers | W 60.5, H 76, D 26 | 22g |
| PV-USB-H1 | Standard 1.2 wiring with in line fuse | 1x red 1.2m, 1x black 1.2m, 1x 2A fuse | 50g |
| PV-USB2-A | USB 'A', Single output charger only 12/24-5V, USB 2.1A | 113 x 24 x 15 | 17g |
| PV-USB2-C | USB 'C', Single output charger only 12/24-5V, USB 3.0A | 113 x 24 x 15 | 16g |

TECHNICAL DATA

| | |
|--------------------------------------|--|
| Input voltage range | 9-32Vdc |
| Output voltage | 5.2Vdc +/- 0.2V |
| Max Output Power | Single A: 2.1A, Dual A: 3.0A, Single C: 3.0A, Dual C: 3.0A, Dual A & C: 3.6A |
| Application | Charging of USB devices including Apple and Android |
| Transient voltage protection | Meets ISO7637-2 International standard for 12/24V vehicles |
| Output noise | <50mV pk-pk |
| Off load current (quiescent current) | <2.5mA |
| Isolation | Non-isolated >400Vrms between casing and terminals |
| Power conversion efficiency | 90% |
| Operating temperature | -25°C to +55°C to meet this specification table |
| Storage temperature | -40°C to +100°C |
| Operating humidity | 95% max., non-condensing |
| Casework | Dark grey polycarbonate body, contrasting trim ring |
| Connections | Input: 6.3mm push-in flat blade connectors Output: USB type-A single/double socket, USB type-C socket |
| Output indicator | Blue LED output indication |
| Mounting method | 30mm diameter hole, with rear nut or front fit bezel |
| Safe area protection: | Over Current Over heat Overvoltage and Undervoltage Reverse Polarity Transients Catastrophic protection |
| Approvals | 2014/30/EU The general EMC directive Regulation 10 The automotive directive 93/68/EEC The CE marking directive IP65 approved (PV65R and PVPWp) Regulation R118 (Automotive Fire) |
| Designed to | EN50498, ISO 7637-2, R118 & R080 |
| Markings | CE, UKCA and E marked |
| IP Rating | IP30/IP65 according to product selection (For IP65 USB connector excluded). Cleaning: wipe with damp cloth, do not spray. |

Version: 2307