



POWERVERTER RAIL USB CHARGERS

12/24VDC USB TYPE A & C CHARGER IP65 PROTECTED

A & C PORT USB CHARGING FOR 12V AND 24VDC APPLICATIONS CERTIFIED TO EN45545-2, EN50121-3-2 AND EN61373 (ROLLING STOCK)

The widespread use of smartphones and computer tablets has created an increasing need for user accessible, on the move charging systems. The PowerVerter PR65R Railway Range is specifically designed to meet all requirements for rolling stock applications. These units can easily be installed into seat backs (space permitting), under the seat, directly into carriage walls, or tabletops using the suitable mounting pods available.

These chargers are available in both standard (secured from the rear with a nut) or front fitting, secured by three screws, covered with a discreet cover ring. Ingress protection is to IP65 (not connectors).

Installations can be carried out two ways:

For systems already galvanically isolated, the PR65R can be connected directly to the electrical system (either 12V or 24V). These units have been approved to EN50155.

If the system specification requires galvanic isolation, then the PR65R range units can be used in conjunction with the Alfatronix DC-DC Railway isolated converters such as PRI24-12 072, PRI72-12 144 or PRI110-12 288. These units have also been tested to EN 50155. We recommend this option.

Please consult the PowerVerter Railway DC-DC Voltage Converters leaflet for more information and the full range of products available.

Alfatronix products have been tested to Rail Fire EN45545-2.

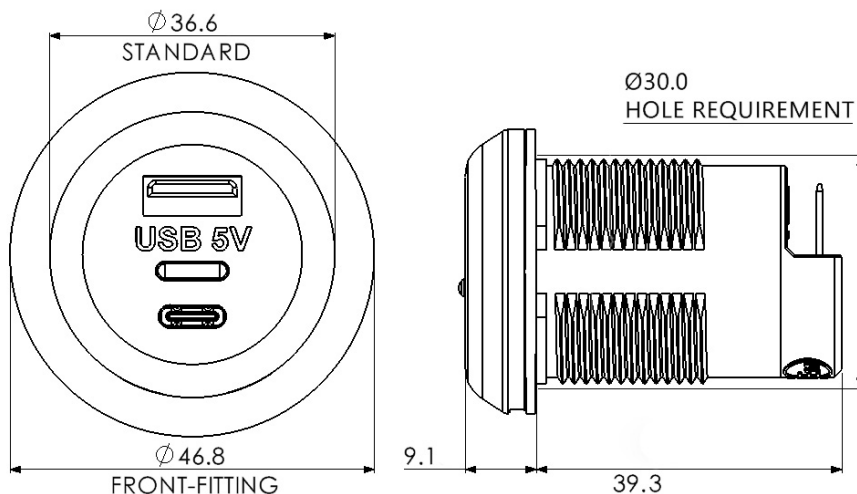

All dimensions in mm.

THE RANGE

All units are installed through a 30mm hole. Standard format units are retained by a rear nut while the front fit versions include a bezel with tamperproof cover ring. Input power is by way of two 6.3mm push-on flat fit automotive terminals.

Electronically the designs include reverse polarity protection and the output withstands short circuit current and will return back to full operation when the short is removed.

SAFETY

A requirement of the USB standard is that the metal cage around the USB plugs and sockets is connected to

ground (zero volts). If a USB charger is to be used in an application with a positive ground, i.e. battery/supply positive terminal is connected to the vehicle chassis, then there is a risk that the exposed metal cage of any USB cable could come in contact with the positive connected chassis, causing uncontrolled heating of the USB cable and USB charger and potentially creating a hazard.

In positive ground applications, the use of an isolated Alfatronix Converter is required to be installed between the positive ground supply and the input of the USB charger. Please refer to the PRI DC-DC datasheet.



PR65R-AC, standard fit AC USB charger secured into place with locking nut.

The PR65R range has the following key benefits:

- Both type-A and type-C outputs
- Apple and Android compatible
- Carriage wall, seat back or underseat and tabletop pod configurations
- LED output indicator
- IP65 ingress protection
- CE and UKCA marked



PR65R-ACFf, front fitting version can be screwed in place from the front, then covered with the attractive ring to avoid tampering.

WARRANTY

The PR65R range of chargers are manufactured using rugged components to provide years of service in demanding commercial environments and are covered by a three year return to base guarantee.

POWERVERTER RAIL USB CHARGERS

Part Number	Description	Dimensions (mm)	Weight
PR65R-AC	USB 'A' & 'C' Dual output rugged, IP65 12/24-5V, 3.6A	Ø37 x 49; Hole Ø30; Rearspace typ.36	38g
PR65R-C	USB 'C' Single output rugged, IP65 12/24-5V, 3.0A	Ø37 x 49; Hole Ø30; Rearspace typ.36	28g
PR65R-ACff	USB 'A' & 'C' Dual output rugged, IP65 12/24-5V, 3.6A, front fit	Ø47 x 49; Hole Ø30; Rearspace typ.36	40g
PR65R-Cff	USB 'C' Single output rugged, IP65 12/24-5V, 3.0A, front fit	Ø47 x 49; Hole Ø30; Rearspace typ.36	30g

Accessories

USB-POD	Under-seat mounting pod for USB chargers	W 60, H 52, D 80	69g
USB-TPOD	Table mounting pod for 2x USB chargers	W 103, H 44.5, D 88	73g

The USB 'A' & 'C' dual output or 'C' single output can also be installed with the USB-POD or USB-TPOD. Please ask our sales team.

TECHNICAL DATA

Input voltage range	9-32Vdc												
Output voltage	5.2Vdc +/- 0.2V												
Max Output Power	Dual A & C: 3.6A, Single C: 3.0A												
Application	Charging of USB devices including Apple and Android												
Transient voltage protection	EN50121-3-2 to EN61000-4-4												
Electrostatic discharge	EN50121-3-2 to EN61000-4-2												
RF Immunity	Conducted: EN50121-3-2 to EN61000-4-6, Radiated to EN61000-4-3												
RF Emissions	EN50121-3-2 to EN55016-2-3 and EN55016-2-1												
Surges	EN50121-3-2 to EN61000-4-5												
Vibration, Shock, Impact	EN61373												
Output noise	<50mV pk-pk												
Off load current (quiescent current)	<2.5mA												
Isolation	Non-isolated >400Vrms between casing and terminals												
Power conversion efficiency	90%												
Operating temperature	-25°C to +55°C to meet this specification table												
Storage temperature	-40°C to +100°C												
Operating humidity	95% max., non-condensing												
Casework	Dark grey polycarbonate body, contrasting trim ring												
Connections	Input: 6.3mm push-on flat blade connectors Output: USB type-A socket, USB type-C socket												
Output indicator	Blue LED output indication												
Mounting method	30mm diameter hole, with rear nut or front fit bezel												
Safe area protection:	<table border="0"> <tr> <td>Over Current</td> <td>Limited by current sensing circuit</td> </tr> <tr> <td>Over heat</td> <td>Limited by temperature sensing circuit</td> </tr> <tr> <td>Overvoltage and Undervoltage</td> <td>Limited by sensing circuit</td> </tr> <tr> <td>Reverse Polarity</td> <td>Protected by sensing circuit</td> </tr> <tr> <td>Transients</td> <td>Protected by filters and rugged component selection</td> </tr> <tr> <td>Catastrophic protection</td> <td>Internal fuse (external fusing recommended)</td> </tr> </table>	Over Current	Limited by current sensing circuit	Over heat	Limited by temperature sensing circuit	Overvoltage and Undervoltage	Limited by sensing circuit	Reverse Polarity	Protected by sensing circuit	Transients	Protected by filters and rugged component selection	Catastrophic protection	Internal fuse (external fusing recommended)
Over Current	Limited by current sensing circuit												
Over heat	Limited by temperature sensing circuit												
Overvoltage and Undervoltage	Limited by sensing circuit												
Reverse Polarity	Protected by sensing circuit												
Transients	Protected by filters and rugged component selection												
Catastrophic protection	Internal fuse (external fusing recommended)												
Approvals	93/68/EEC The CE marking directive 2014/30/EU The general EMC directive (UKCA 2016 No 1091) Railway Standards to EN50155 (EN50121-3-2), EN45545-2 and EN61373.												
Markings	CE and UKCA												
IP Rating	IP65 (USB connector excluded). Cleaning: wipe with damp cloth, do not spray.												