

ALFACHARGE WIRELESS CHARGER AL2

12/24VDC COMBINED WIRELESS AND USB CHARGER

AL2 SERIES WIRELESS CHARGER PODSOLE FOR INTEGRATION INTO VEHICLE EQUIPMENT

Wireless charging is increasingly becoming the preferred method of maintaining battery power in mobile devices, with most of the latest designs from the major manufacturers including wireless charging as standard.

The AL2 series Podsole has been elegantly designed to allow passengers to charge both wireless and USB charging devices on the move. The two retaining clips and non-slip buttons secure the device into place permitting the wireless charging of all wireless enabled smart devices, whilst the USB connector can charge another device like a phone or tablet simultaneously.

The Podsole is extremely versatile and can be connected to both 12Vdc and 24Vdc electrical systems without adjustment. It has also been designed for both OEM and retrofit applications and can be mounted to any seat back using 4 screws which are hidden behind tamperproof covers. Due to the durable polyurethane compound encompassing the electronic components, comprehensive protection is provided against dust and liquid ingress.

The advanced electronic design will detect the charge status of the device and alter the charging process accordingly. This ensures that whatever device is connected, be it Apple, Android, phone or tablet, it will always be charged as fully as time and capacity allow. Two LEDs indicate the chargers are operational.



THE RANGE

The Alfacharge range has been designed to meet the rigorous standards required for on board commercial vehicle applications including EN50498, EN50155 & ISO7637-2, and is both CE and E marked (Reg10). The casings are made from V0-rated (self-extinguishing) high impact polycarbonate and the PCB is populated by computer-controlled SMT for maximum accuracy and durability.

SAFETY

Wireless chargers require that there is no metal between the device providing the charge and the device being charged, as

this metal could heat up to a hazardous temperature.

The AL series of wireless chargers use sophisticated Foreign Object Detection (FOD) algorithms to detect metal objects placed between the charger and the device being charged and prevent the charging process from starting if metal is detected.

It is the responsibility of the installer to ensure correct operation of the FOD functions in the end application of the product, and that during use, no metal is expected to be placed between the wireless charger and the device being charged.



Designed for integration into passenger vehicles.

Accepts both 12Vdc and 24Vdc.

- Approved to EN50498, EN50155 & ISO7637-2. E marked (Reg10) and CE marked.
- Phone power communicates every second to establish correct charge.
- Foreign object detection & activation.
- Convenient wide input of 9-32Vdc for wireless and USB charging in one extrusion.
- LED to confirm correct operation.



It is recommended that these units are fused individually with a 2Amp fuse (24V systems) or a 3Amp fuse (12V systems).

WARRANTY

The AL2 Podsole Series of combined wireless chargers and USB Chargers are manufactured using rugged components to provide years of service in demanding commercial environments and are covered by a three year return to base warranty.

ALFACHARGE PART SELECTION

Part Number	Description	Dimensions	Weight
AL2-WS	Combined Wireless and USB Charger	187 x 122 x 26mm	225g

Other configurations are available, please speak to our sales team

TECHNICAL DATA

Input voltage range	9-32Vdc
Output power	Wireless Charger: Nominal 5W; USB Charger: 10W for BC1.2 and 12W for Q.C 3.0
Application	Wireless Charger: Charges wireless enabled devices; USB Charger: Charges all USB devices inc. Apple and Android
Transient voltage protection	Meets ISO7637-2 International standard for 12/24V vehicles and EN61000.4.4 and 4.5 for rail
Tx-Range	Nominal 5mm
Off load current (quiescent current)	Combined 10mA
Power conversion efficiency	Wireless Charger: 50% - 60%; USB Charger: 90%
Operating temperature	-25°C to +40°C
Storage temperature	-25°C to +100°C
Operating humidity	95% max., non-condensing
Casework	Grey polycarbonate body
Connections	Input: 6.3mm push-in flat blade connectors Output: USB type 'A' single socket - tested to 10,000 mating cycles
Output indicator	Green/blue LED output indication
Mounting method	Box with mounting screw holes - screws provided. Can also be installed by clips or other bespoke method
Safe area protection:	Over Current Limited by current sensing circuit Over heat Limited by temperature sensing circuit Overvoltage and Undervoltage Limited by sensing circuit Reverse Polarity Limited by sensing circuit Transients Protected by filters and rugged component selection Catastrophic protection Internal fuse
Approvals	2014/30/EU The general EMC directive Regulation 10 The automotive directive 93/68/EEC The CE marking directive
Designed to	EN50498, EN61373, EN50155, EN45545, EN50121-3-2, ISO 7637-2 & R118
Markings	CE, UKCA and E marked

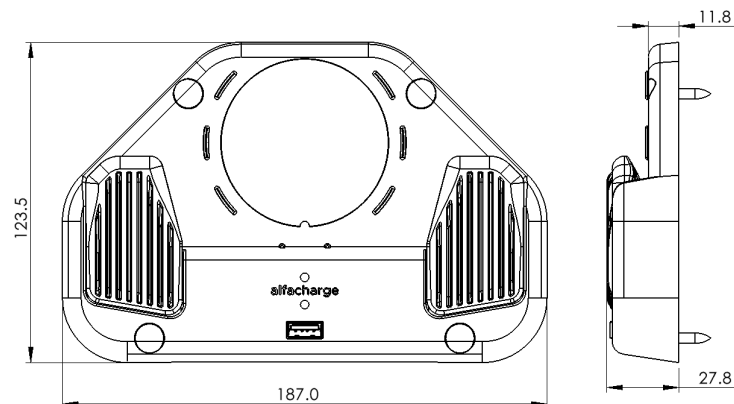

Version: 2307